

WKO-2C-B 1000

$I_{PN} = 1000\text{ A}$

RoHs compliant



REO current transducers are designed for the measurement of DC, AC and pulsed currents using closed loop technology. The REO dual-core technology allows improved accuracy with high immunity to external interferences.

Features

- Closed loop technology
- Bidirectional and isolated current measurement
- Current output
- Modular design
- REO dual-core technology
- All materials fulfil UL requirements



Advantages

- High measurement accuracy of 0.3%
- High linearity
- Wide frequency range
- High immunity to external interference
- High current overload capability
- Low temperature drift
- Universal mounting options due to modular design
- Meets the safety standards required in railway technology: EN 50178, EN 50155:2007 and IEC 61373:2010

Applications

- Traction
- Variable speed control of 3-phase AC-motor and servo motor drives
- Propulsion inverters
- Uninterruptable power supplies
- All kind of switched mode power supplies
- Railway applications

Standards

- EN 50155:2007 Railway applications - Electronic equipment used on rolling stock
- EN 50121-3-2:2006 Railway applications - Electromagnetic compatibility
- EN 50178:1997 Electronic equipment for use in power installations
- UL 94V-0

Electrical Data

over ambient operating temperature (unless otherwise noted)

Symbol	Parameter	Unit	Min	Typ	Max	Remarks
I_{PN}	Primary nominal current	[A]		1000		
I_{PM}	Primary current, measuring range	[A]		± 2700		
I_{SN}	Secondary nominal current	[mA]		200		
I_{SM}	Secondary current, measuring range	[mA]		± 540		
N_S	Number of secondary turns			5000		
R_S	Secondary coil resistance	[Ω]		42		@ $T_a=85^\circ\text{C}$
R_M	Measuring resistance	[Ω]	0			see $R_M(I_P)$ diagram
U_C	Supply voltage	[V]	± 14.25		± 25.2	
I_C	Current consumption	[mA]		$17 + I_S$ $26 + I_S$		$U_C = \pm 15\text{V}$ $U_C = \pm 24\text{V}$
I_O	Offset current	[A]		± 0.5		referred to primary (0,1%)
I_{OM}	Magnetic offset current	[A]		± 0.5		referred to primary (0,04%)
ϵ_G	Sensitivity error	[%] of I_{PN}		± 0.15		
ϵ_L	Linearity error	[%] of I_{PN}		± 0.1		
X_G	Overall accuracy	[%] of I_{PN}		± 0.3		@ $T_a = -40^\circ\text{C} \dots +85^\circ\text{C}$
t_{ra}	Reaction time	[ns]		300		@ $T_a = 25^\circ\text{C}$; to 10% of I_S
t_r	Step response time	[ns]		300		@ $T_a = 25^\circ\text{C}$; to 10-90% of I_S
BW	Frequency bandwidth	[kHz]		120	200	@ $T_a = 25^\circ\text{C}$; -1dB

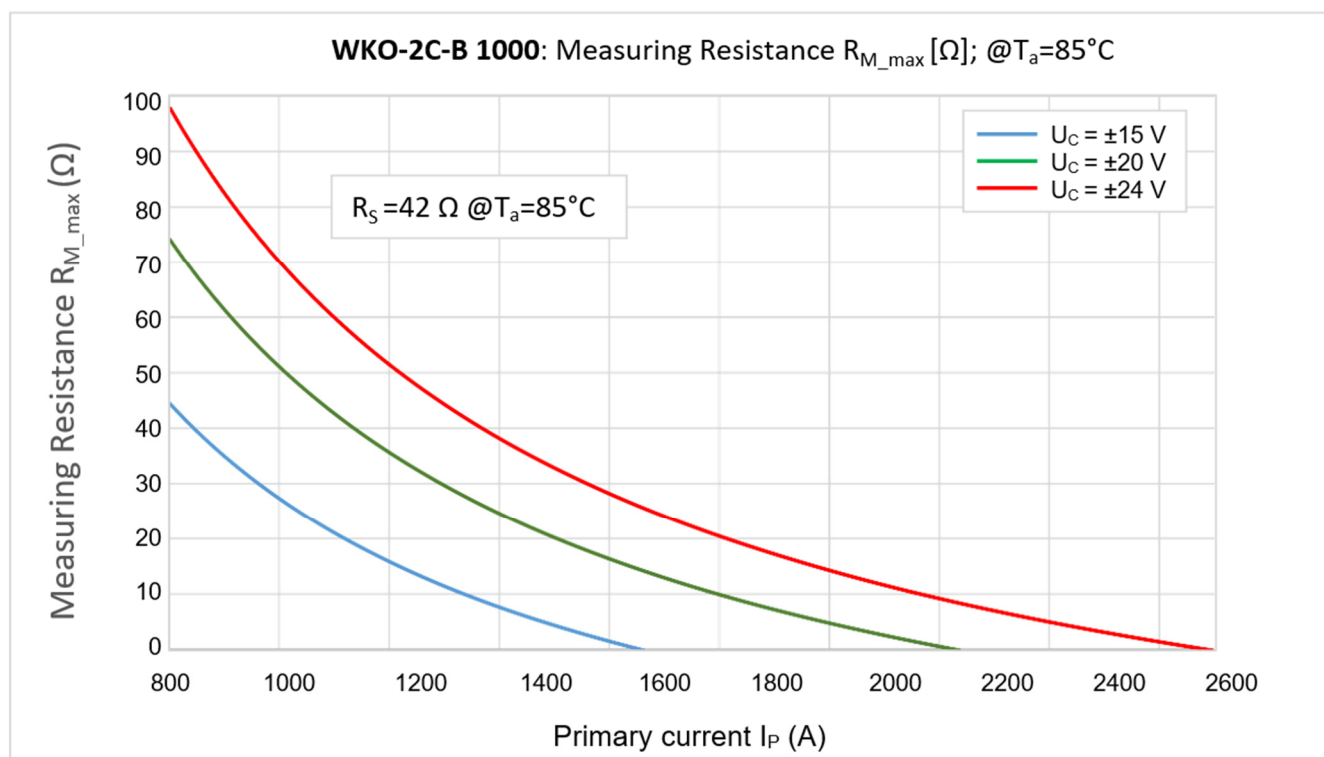

Absolute Maximum Ratings

Parameter	Symbol	Unit	Value
Max. supply voltage (-40°C..+85°C)	$\pm U_C$	[V]	25.2
Max. busbar temperature	T_B	[°C]	100
Max. permanent primary current	I_{PN}	[A _{rms}]	1000

Stresses beyond those listed under *Absolute Maximum Ratings* may cause permanent damage to the device. These are stress ratings only, and functional operation of the device at these or any other conditions beyond those indicated *Electrical Data* is not implied. At maximum stress, derating must be considered!

Important

- The installation of REO products should be carried out in accordance with REO installation guides.
- The applied connectors are not tested for the respective application.
- Apply an isolated voltage supply
- The busbar temperature must not exceed $T_B=100^\circ\text{C}$

Isolation characteristics

Parameter	Symbol	Unit	Value	Remarks
RMS voltage for AC insulation test, 50Hz, 1 Min	U_d	[kV]	6	$1000\text{V} < U_{\text{System}} < 3600\text{V}$
Impulse test voltage 1.2/50 μs	U_i	[kV]	12.5	$1000\text{V} < U_{\text{System}} < 3600\text{V}$; Kat. IV
Insulation resistance	R_{is}	[M Ω]	200	@500V _{rms}
Creepage distance	d_{cp}	[mm]	20	
Clearance	d_{ci}	[mm]	18	
Comparative Tracking Index	CTI		600	
Partial discharge	$Te/Ta@10\text{pC}$	[kV _{rms}]	2.59/2.55	IEC 60270
Housing				UL 94V-0
Potting material				UL 94V-0

General Data

Parameter	Symbol	Unit	Value	Remarks
Ambient operating temperature	T_A	[°C]	-40..+85	
Ambient storage temperature	T_s	[°C]	-45..+90	
Weight	m	[g]	700	

Mechanical characteristics

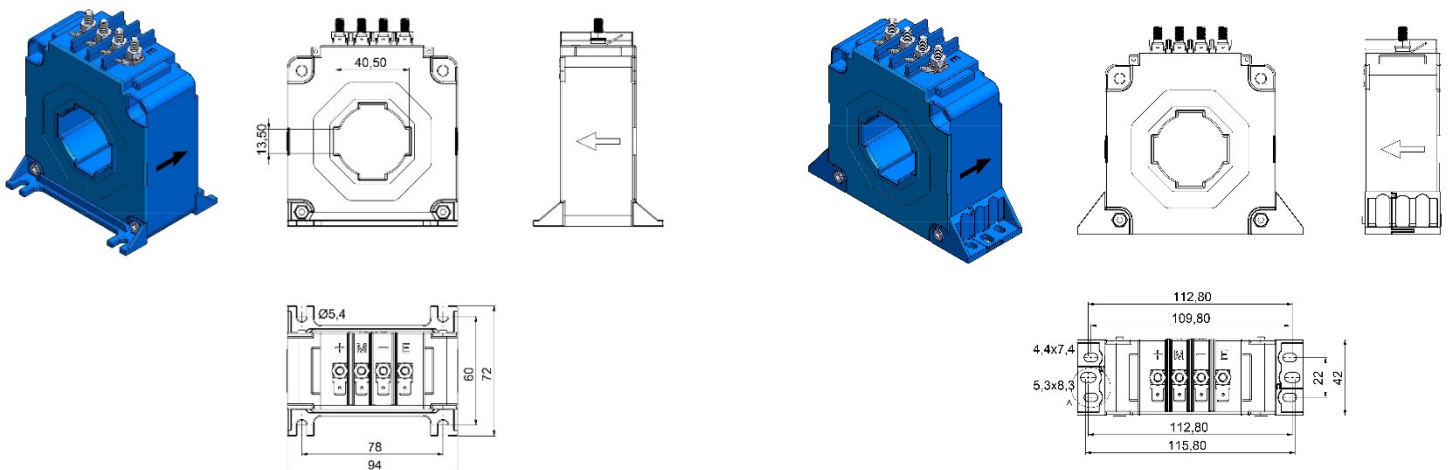
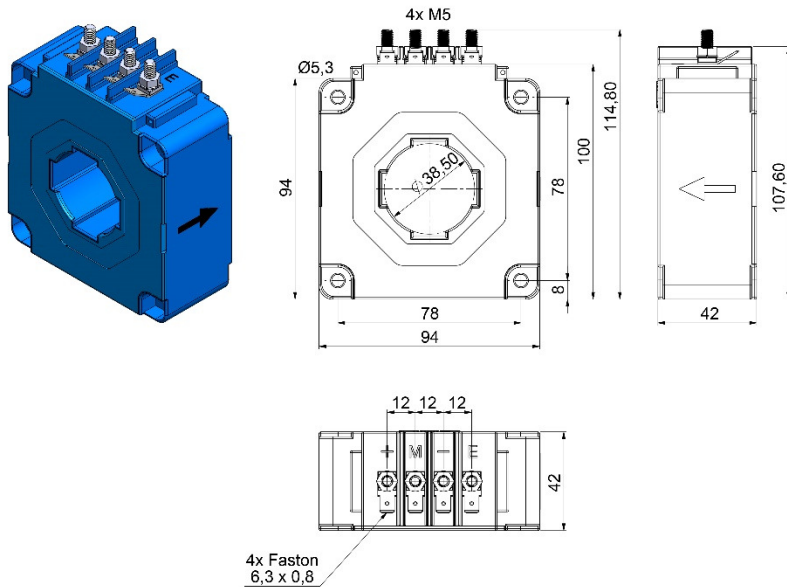

Remarks

- The output current is positive when the primary current flows in the direction indicated by the arrow on the housing.