

JB1 Accelerometer



Quartz flexible accelerometer series is a high-precision military inertial navigation class accelerometer with excellent long-term stability, repeatability, start-up performance, environmental adaptability and high reliability. It can be used for both static and dynamic testing, and it is also a standard vibration sensor and inclination sensor.

The output current of the product has a linear relationship with the force or acceleration received. Users can select the appropriate sampling resistance through calculation to achieve high precision output. And according to user needs built-in temperature sensor, used to offset value and scale factor compensation, reduce the impact of environmental temperature.

Applications: inertial measurement of military high-precision inertial navigation system and vibration isolation test of precision instruments and equipment in aerospace, aviation, ships, weapons and other fields.

Features

1. Excellent turn-on repeatability performance
2. Environmentally rugged
3. Analog output
4. Field adjustable range
5. Three fastener precision mounting flange
6. Internal temperature sensor for thermal compensation (option)
7. For the scale factor we can adjust for you.

Configuration Drawing and interface

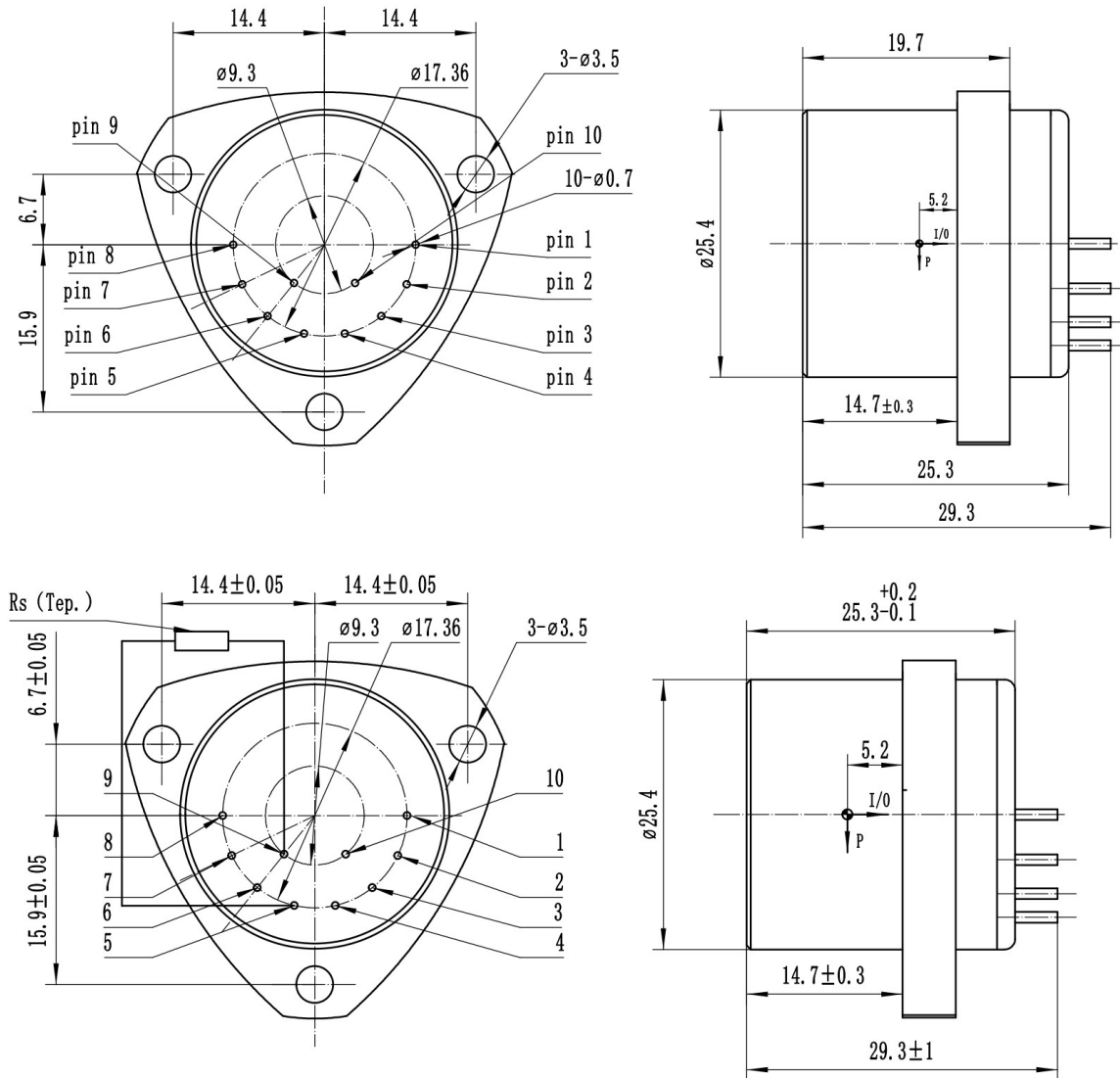

Mark: The temperature sensor is AD590; Point 10 is the high power. The point 9 is the low power. The point 9 and power ground use one platinum resistance; the value is 1K, the thermal coefficient is less than 5ppm.

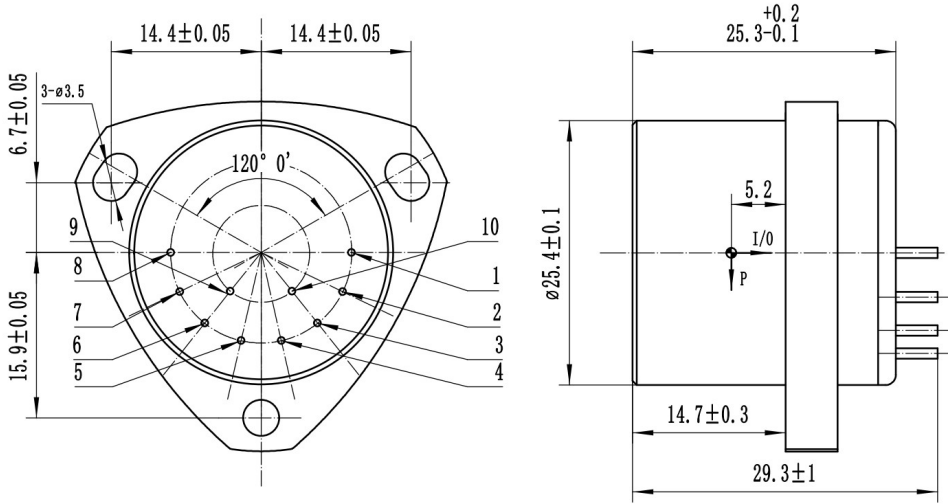

Install hole is U type

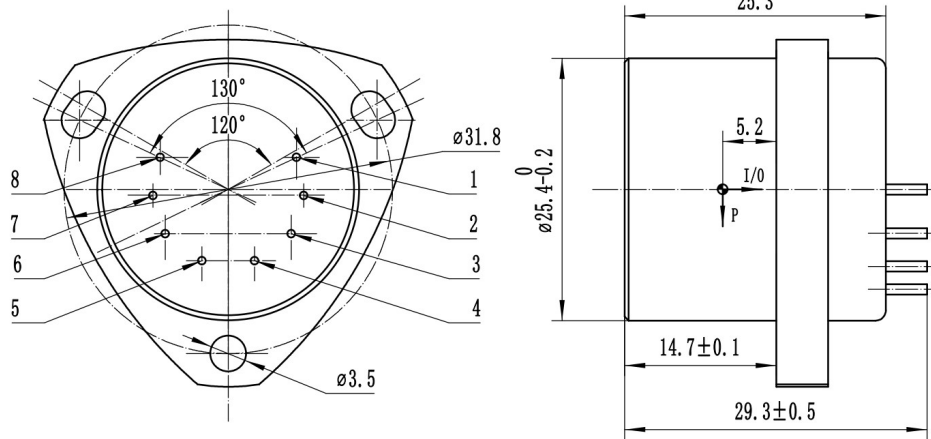

Install hole is U type, pin number is 8

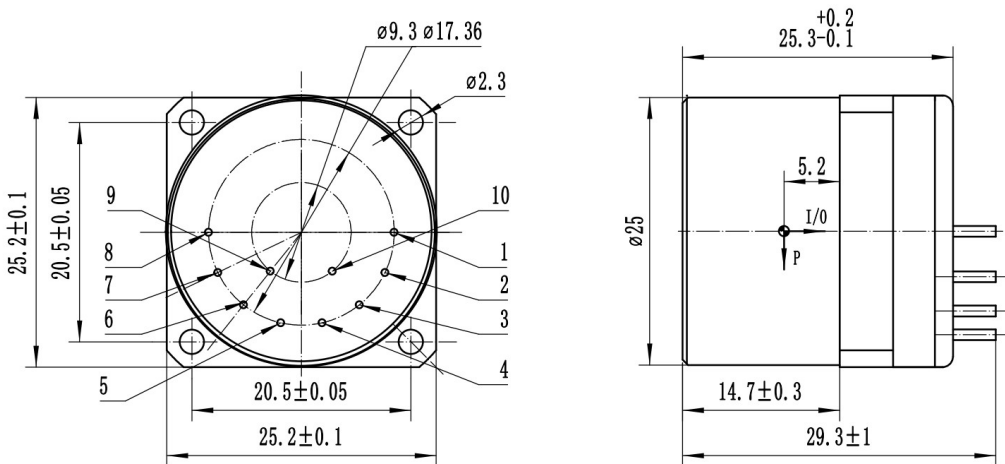

The outline is square

Performance characteristics

S/No	Parameters	JB1-01	JB1-02	JB1-03
1	Range	±50g	±50g	±50g
2	Threshold /Resolution	5μg	5μg	5μg
3	Bias k0/k1	≤±3mg	≤±3mg	≤±5 mg
4	Scale factor k1	1.05~1.30 mA/g	1.05~1.30 mA/g	1.05~1.30 mA/g
5	Class II nonlinearity coefficient k2/k1	≤±10μg /g ²	≤±15μg /g ²	≤±20μg /g ²
6	0g 4 hours short time stability	≤10 μg	≤10μg	≤15 μg
7	1g 4 hours short time stability	≤10 ppm	≤10 ppm	≤15 ppm
8	Bias drift Sigma k0(1σ, one month)	≤10 μg	≤20 μg	≤30 μg
9	Repeatability of scale factor Sigma k1/k1(1σ, one month)	≤15ppm	≤30 ppm	≤50 ppm
10	Class II nonlinearity Coefficient repeatability k2/k1(1σ, one month)	≤±10 μg /g ²	≤±20 μg /g ²	≤±30 μg /g ²
11	Bias thermal coefficient	≤±10 μg /°C	≤±30 μg /°C	≤±50 μg /°C
12	Scale factor thermal coefficient	≤±10 ppm /°C	≤±30 ppm /°C	≤±50 ppm /°C
13	Noise (sample resistance 840Ω)	≤5mv	≤8.4mv	≤8.4mv
14	Natural Frequency	400~800 Hz	400~800 Hz	400~800 Hz
15	Bandwidth	800~2500 Hz	800~2500 Hz	800~2500 Hz
16	Vibration	6g(20-2000Hz)	6g(20-2000Hz)	6g(20-2000Hz)
17	Shock	100g,8ms,1/2sin	100g,8ms,1/2sin	100g,8ms,1/2sin
18	Temperature range(Operating)	-55~+85°C	-55~+85°C	-55~+85°C
19	Temperature range(saved)	-60~+120°C	-60~+120°C	-60~+120°C
20	Power	±12~±15V	±12~±15V	±12~±15V
21	Consume current	≤±20mA	≤±20mA	≤±20mA
22	Temp. sensor	Option	Option	Option
23	Size	Φ25.4X30mm	Φ25.4X30mm	Φ25.4X30mm
24	Weight	≤80g	≤80g	≤80g

DISCLAIMER: Specifications are subject to change without notice. kaituo reserves the right to make changes to any product or technology herein to improve reliability, function or design.

Tel: +8613785430963 E-mail: ktjntm2020@vip.163.com

Wechat: 1487974841 <http://www.ktjmyq.com> and en.ktjmyq.com

Updated in March 2023